



TRI-T COMPANY LIMITED

**SPECIFICATION
FOR
LCD MODULE**

ORDER NO : TMBC20464BSP-09

MODULE NO.: TMBC20464BSP-W-G-LED04-YG

DOC.REVISION A00

Customer Approval:

--

	NAME	SIGNATURE	DATE
PREPARED BY	KWOK SHING FU		3 MAR 2004
CHECKED BY	FU SZE HOI		3 MAR 2004
APPROVED BY	FU SZE HOI		3 MAR 2004



TRI-T COMPANY LIMITED

DOCUMENT REVISION HISTORY

Version	DATE	DESCRIPTION	CHANGED BY
A00	3 MAR 2004	First issue	



CONTENTS

Dimensional Outline	1
Functions & Features	2
Mechanical Specifications	2
Block Diagram	2
Power Supply	3
Pin Description	3
Maximum Absolute Limit	4
Electrical Characteristics	4,5,6
Backlight Specification	7
Control and Display Command	8
Standard Character Pattern	9
Relationship between DDRAM and CGRAM	10
Initializing by Instruction	11,12
Software Examples	13
Quality Specifications	14~20



1.DIMENSIONAL OUTLINE

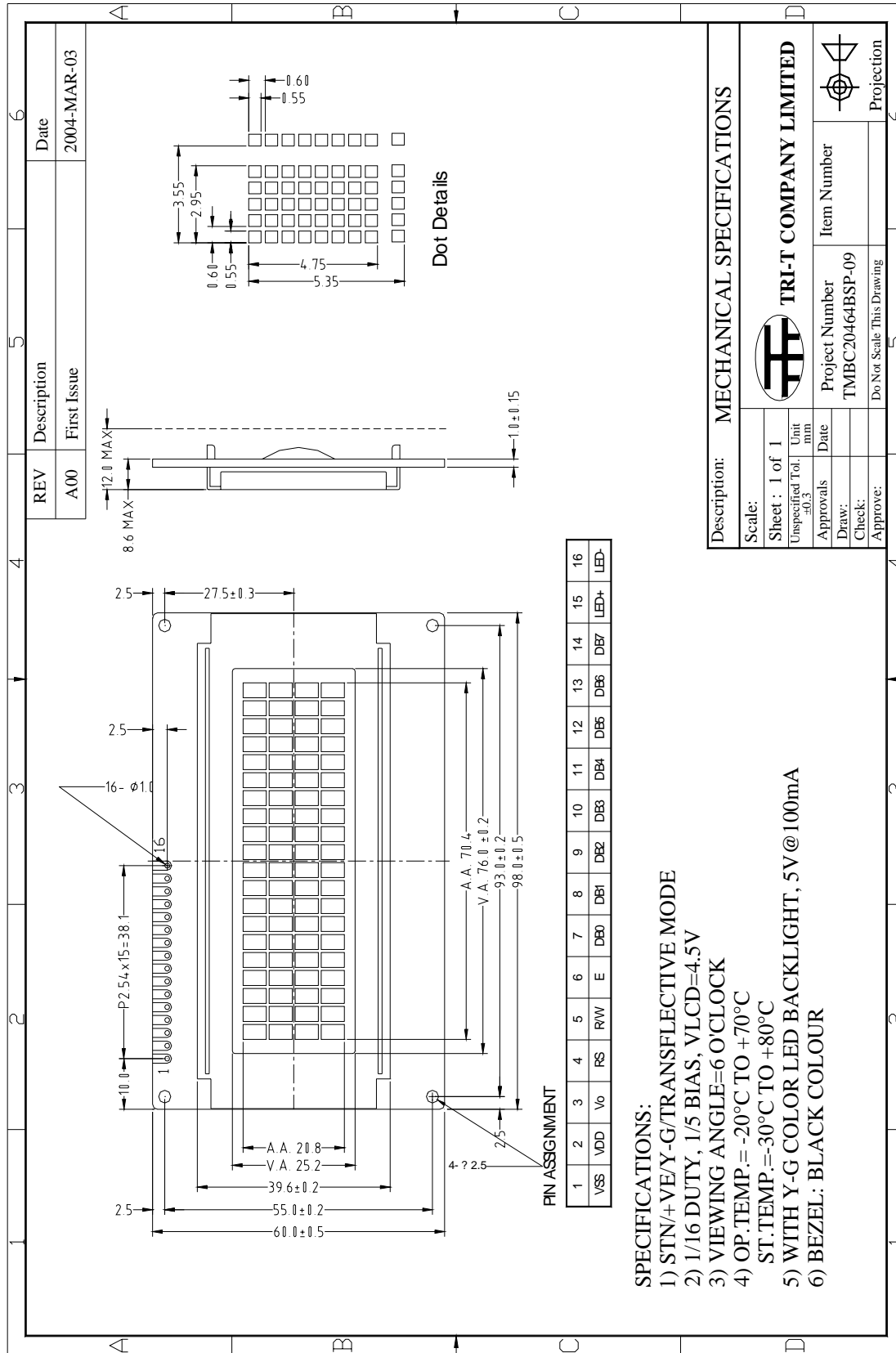



2.FUNCTIONS & FEATURES

- 2-1. Format : 20 characters*4 line
- 2-2. LCD mode : STN, Positive, Y-G, Transflective Mode
- 2-3. LED Color : Yellow Green
- 2-3. Viewing direction : 6 o'clock
- 2-4. Driving scheme : 1/16 Duty cycle, 1/5 Bias
- 2-5. Low power operation : Power supply voltage range (V_{DD}): 2.7~5.5V
- 2-6. Internal Memory : CGROM (10,880bits)
: CGRAM (64*8bits)
: DDRAM (80*8bits)
- 2-7. Easy interface with a 4-bit or 8-bit MPU

3.MECHANICAL SPECIFICATIONS

- 3-1. Module size : 98.00mm(L) x 60.00mm(W) x 12.0 mm MAX (D)
- 3-2. Viewing area : 76.00mm(L) x 25.2mm(W)
- 3-3. Character pitch : 5.35mm(L) x 3.55mm(W)
- 3-4. Character size : 4.75mm(L) x 2.95mm(W)
- 3-5. Dot pitch : 0.60mm(L) x 0.60mm(W)
- 3-6. Dot size : 0.55mm(L) x 0.55mm(W)

4.BLOCK DIAGRAM

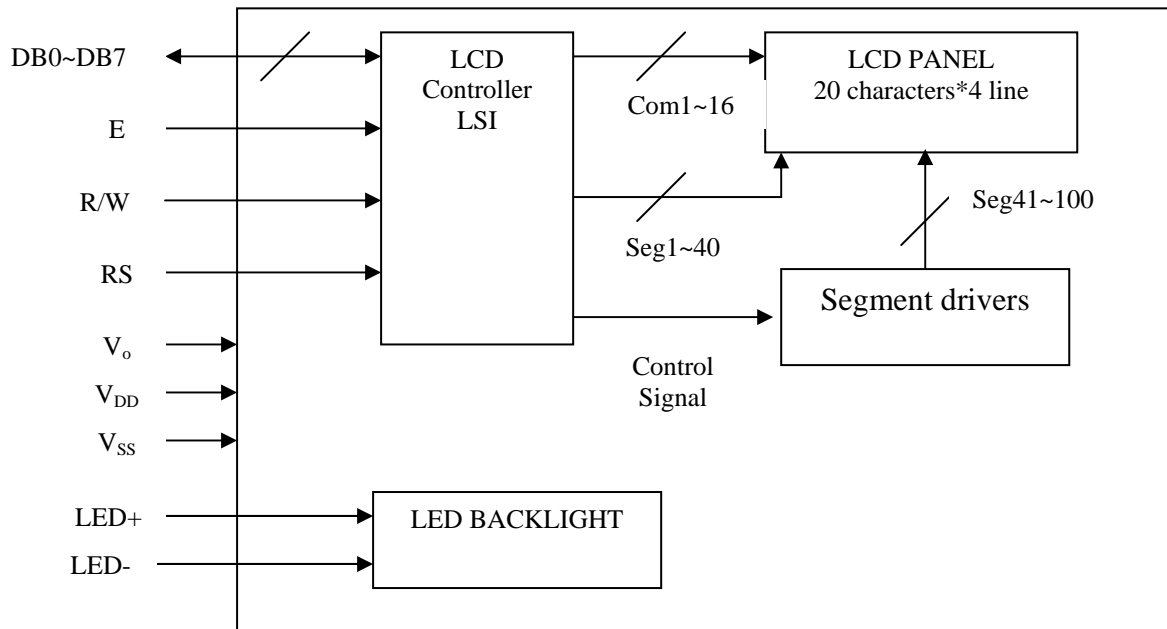



5. POWER SUPPLY

5-1. Dual Power

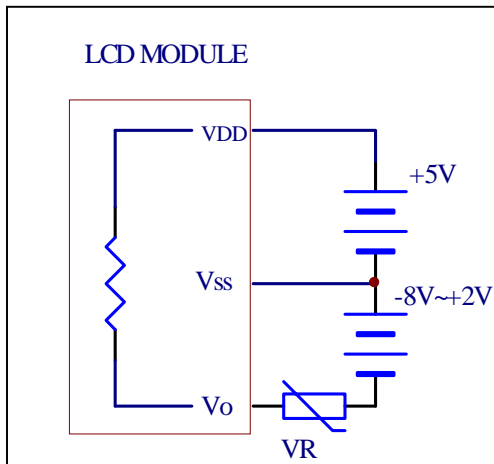

$V_{DD}-V_0$ =Operating voltage for LCD
 $VR=10k\Omega\sim 20k\Omega$

6. PIN DESCRIPTION

Pin no.	Symbol	Function
1	V_{SS}	Ground
2	V_{DD}	Supply voltage for logic circuit
3	V_0	Voltage level for LCD driving
4	RS	Selects register data "H" and instruction "L"
5	R/W	Use as read/write select input
6	E	Use as read/write enable signal
7	DB0	Display data signal
8	DB1	
9	DB2	
10	DB3	
11	DB4	
12	DB5	
13	DB6	
14	DB7	
15	LED(+)	Anode of LED backlight
16	LED(-)	Cathode of LED backlight



7. MAXIMUM ABSOLUTE LIMIT (T=25°C)

Item	Symbol	Standard value	Unit
Power supply voltage for logic	V _{DD}	-0.3 ~ +7.0	V
Driver supply voltage for LCD (V _{DD} -V ₀)	V _{LCD}	V _{DD} -12.0 ~ V _{DD} +0.3	V
Input voltage	V _{IN}	-0.3 ~ V _{DD} +0.3	V
Operating temperature	T _{opr}	-20 ~ +70	°C
Storage temperature	T _{stg}	-30 ~ +80	°C

Note: Voltage greater than above may damage the module

8. ELECTRICAL CHARACTERISTICS

8-1 DC Characteristics (V_{DD}=4.5~5.5, T_a=+25°C)

Item	Symbol	Min	Typ	Max	Unit	Applicable terminal	Test condition
Operating voltage	V _{DD}	4.5	5	5.5	V	-	-
Supply current	I _{DD}	-	2.5	4.0	mA	-	f _{OSC} =250KHZ
Input voltage	V _{IL}	-0.3	-	0.6	V	RS, R/W	-
	V _{IH}	2.2	-	V _{DD}	V	E, D0~D7	-
Output voltage	V _{OH1}	2.4	-	V _{DD}	V	D0~D7	I _{OH} =-0.1mA
	V _{OL1}	-	-	0.4	V		I _{OL} =0.1mA
	V _{OH2}	0.9V _{DD}	-	V _{DD}	V	CL1, CL2, M, D	I _{OH} =-40uA
	V _{OL2}	-	-	0.1V _{DD}	V		I _{OL} =40uA
Input high current	I _{IH}	-2.0	-	2.0	μA	RS, R/W, D0~D7	V _{DD} =5V
Input low current	I _{IL}	-20	-50	-100	μA	RS, R/W, D0~D7	V _{DD} =5V
LCD driving voltage	V _{LCD}	4.3	4.5	4.7	V	V _{DD} -V ₀	T _a =25°C



8-2 AC Characteristics ($V_{DD}=5V \pm 10\%$, $V_{SS}=0V$, $T_a=+25^\circ C$)

8-2-1. Write mode (Writing data from MPU to LCD MODULE)

Characteristic	Symbol	Min	Typ	Max	Unit	Test pin
E cycle time	t_c	500	-	-	ns	E
E rise time	t_r	-	-	20	ns	E
E fall time	t_f	-	-	20	ns	E
E pulse width (High, Low)	t_w	230	-	-	ns	E
R/W and RS set-up time	t_{su1}	40	-	-	ns	R/W,RS
R/W and RS hold time	t_{h1}	10	-	-	ns	R/W,RS
Data setup time	t_{su2}	80	-	-	ns	DB0~DB7
Data hold time	t_{h2}	10	-	-	ns	DB0~DB7

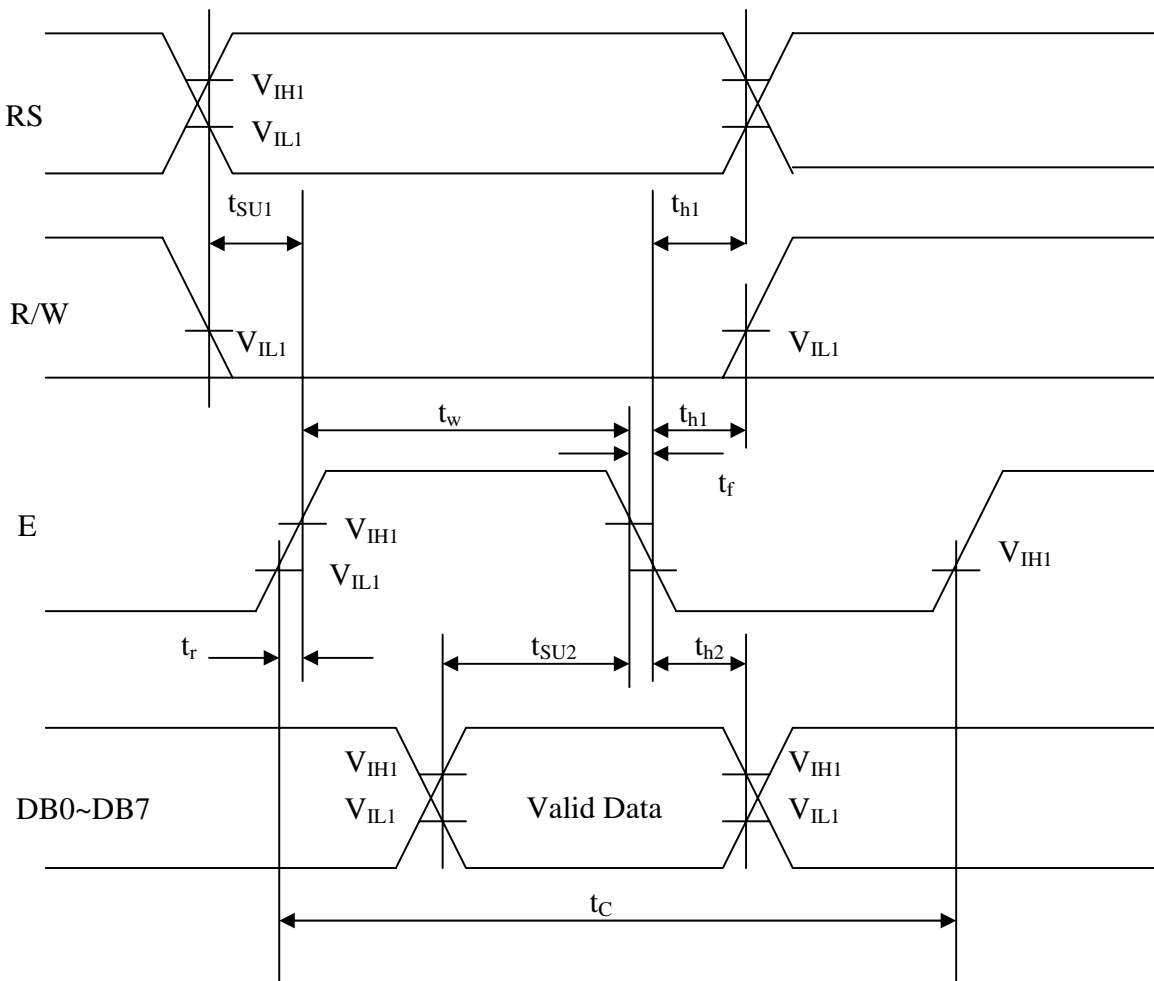



8-2-2. Read mode (Reading data from LCD MODULE to MPU)

Characteristic	Symbol	Min	Typ	Max	Unit	Test pin
E cycle time	t_c	500	-	-	ns	E
E rise time	t_r	-	-	20	ns	E
E fall time	t_f	-	-	20	ns	E
E pulse width (High, Low)	t_w	230	-	-	ns	E
R/W and RS set-up time	t_{su}	40	-	-	ns	R/W,RS, E
R/W and RS hold time	t_h	10	-	-	ns	R/W,RS, E
Data output delay	t_D	-	-	120	ns	DB0~DB7
Data hold time	t_{DH}	5	-	-	ns	DB0~DB7

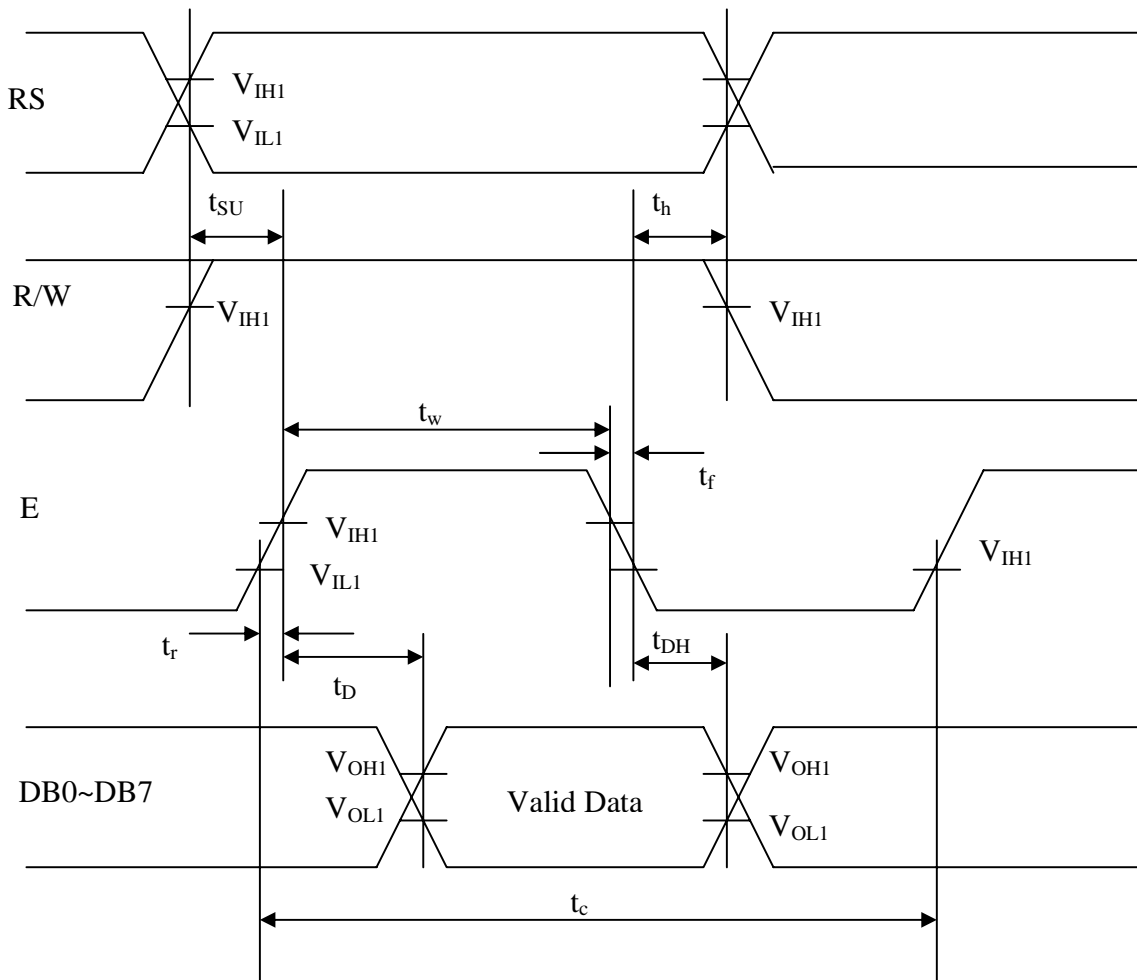



9.BACKLIGHT SPECIFICATIONS

9-1.Absolute maximum rating

9-1.Absolute maximum rating

Item	Symbol	Ratings	Unit
Peak forward current	Ifp	150	mA
Reverse voltage	Vr	8	V
Power dissipation	Pd	800	mW
Operating temperature	Topr	-20~+70	°C
Storage temperature	Tstg	-30~+80	°C

9-2.Electrical specifications

Item	Symbol	Min	Type	Max	Unit	Conditions
Luminous intensity	Lv	100	150	-	cd/m ²	IF=100mA Ta=25°C
Peak emission wavelength	λ_p	-	-	-	nm	
Spectral line half width	$\Delta\lambda$	-	-	-	nm	
Forward voltage	Vf	4.8	5.0	5.2	V	
Reverse current	Ir	-	-	1800	μA	VR=8V



10.CONTROL AND DISPLAY COMMAND

Command	RS	R/W	DB7	DB6	DB5	DB4	DB3	DB2	DB1	DB0	Execution time (fosc=270khz)	Description			
Clear display	L	L	L	L	L	L	L	L	L	H	1.52ms	Write "20H" to DDRAM and set DDRAM address o "00H" from AC			
Return home	L	L	L	L	L	L	L	L	L	H	X	1.52ms	Return cursor to it's original position if shifted		
Entry mode set	L	L	L	L	L	L	L	L	H	I/D	SH	38μs	I/D: Set cursor move direction		
													I/D	H	Increase
														L	Decrease
													SH: Specifies shift of display		
SH	H	Displayed shifted													
	L	Display is not shifted													
Display on/off	L	L	L	L	L	L	L	H	D	C	B	38μs	Display		
													D	H	Display on
														L	Display off
													Cursor		
													C	H	Cursor on
														L	Cursor off
													Blinking		
B	H	Blinking on													
	L	Blinking off													
Shift	L	L	L	L	L	H	S/C	R/L	X	X	38μs	38μs	SC		
													H	Display shift	
													L	Cursor move	
													R/L	H	Right shift
L	Left shift														
Set function	L	L	L	L	H	DL	N	F	X	X	38μs	38μs	DL	H	8bits interface
														L	4bits interface
													N	H	2 lines display
														L	1 line display
													F	H	5*10 dots
														L	5*7 dots
Set CGRAM address	L	L	L	H	CGRAM address (Corresponds to cursor address)					38μs	CGRAM data is sent and received after this setting				
Set DDRAM address	L	L	H	DDRAM address					38μs	DDRAM data is sent and received after this setting					
Read busy flag & address	L	H	BF	Address counter used for both DDRAM & CGRAM address					0	BF	H	Busy			
											L	Ready			
													-Reads BF indication internal operating is being preformed		
													-Reads address counter contents		
Write data	H	L	Write data					38μs	Write data into DDRAM or CGRAM						
Read data	H	H	Read data					38μs	Read data DDRAM or CGRAM						

X: Don't care



11. STANDARD CHARACTER PATTERN

Upper 4bits Lower 4bit	LLLL	LLLH	LLHL	LLHH	LHLL	LHLH	LHHL	LHHH	HLLL	HLLH	HLHL	HLHH	HHLL	HHLH	HHHL	HHHH
LLLL	CG RAM (1)															
LLLH	(2)															
LLHL	(3)															
LLHH	(4)															
LHLL	(5)															
LHLH	(6)															
LHHL	(7)															
LHHH	(8)															
HLLL	(1)															
HLLH	(2)															
HLHL	(3)															
HLHH	(4)															
HHLL	(5)															
HHLH	(6)															
HHHL	(7)															
HHHH	(8)															



12.RELATIONSHIP BETWEEN DDRAM AND CGRAM

Character code(DDRAM data)								CGRAM address						CGRAM data								Pattern number
D7	D6	D5	D4	D3	D2	D1	D0	A5	A4	A3	A2	A1	A0	P7	P6	P5	P4	P3	P2	P1	P0	
0	0	0	0	x	0	0	0	0	0	0	0	0	0	x	x	x	1	1	1	1	1	pattern1
				.							0	0	1				0	0	1	0	0	
				.							0	1	0				0	0	1	0	0	
				.							0	1	1				0	0	1	0	0	
				.							1	0	0				0	0	1	0	0	
				.							1	0	1				0	0	1	0	0	
				.							1	1	0				0	0	1	0	0	
				.							1	1	1				0	0	0	0	0	
0	0	0	0	x	0	0	1	0	0	1	0	0	0	x	x	x	0	1	1	0	0	pattern2
				.							0	0	1				1	0	0	1	0	
				.							0	1	0				1	0	1	0	0	
				.							0	1	1				0	1	0	0	0	
				.							1	0	0				1	0	1	0	1	
				.							1	0	1				1	0	0	1	0	
				.							1	1	0				0	1	1	0	1	
				.							1	1	1				0	0	0	0	0	
				
0	0	0	0	x	1	1	1	1	1	1	0	0	0	x	x	x	1	1	1	1	1	pattern8
				.							0	0	1				0	0	1	0	0	
				.							0	1	0				0	0	1	0	0	
				.							0	1	1				0	0	1	0	0	
				.							1	0	0				0	0	1	0	0	
				.							1	0	1				0	0	1	0	0	
				.							1	1	0				0	0	1	0	0	
				.							1	1	1				0	0	0	0	0	

CGRAM has up to 5*8 dots 8 characters.

By writing font data to CGRAM, user defined characters can be used

DDRAM ADDRESS OF EACH LINE

Line 1	00	01	02	03	04	05	06	07	08	09	0A	0B	0C	0D	0E	0F	10	11	12	13
Line 2	40	41	42	43	44	45	46	47	48	49	4A	4B	4C	4D	4E	4F	50	51	52	53
Line 3	14	15	16	17	18	19	1A	1B	1C	1D	1E	1F	20	21	22	23	24	25	26	27
Line 4	54	55	56	57	58	59	5A	5B	5C	5D	5E	5F	60	61	62	63	64	65	66	67



13.INITIALIZING BY INSTRUCTION

13-1. 8-bit interface mode

Condition: $f_{osc}=250kHz$

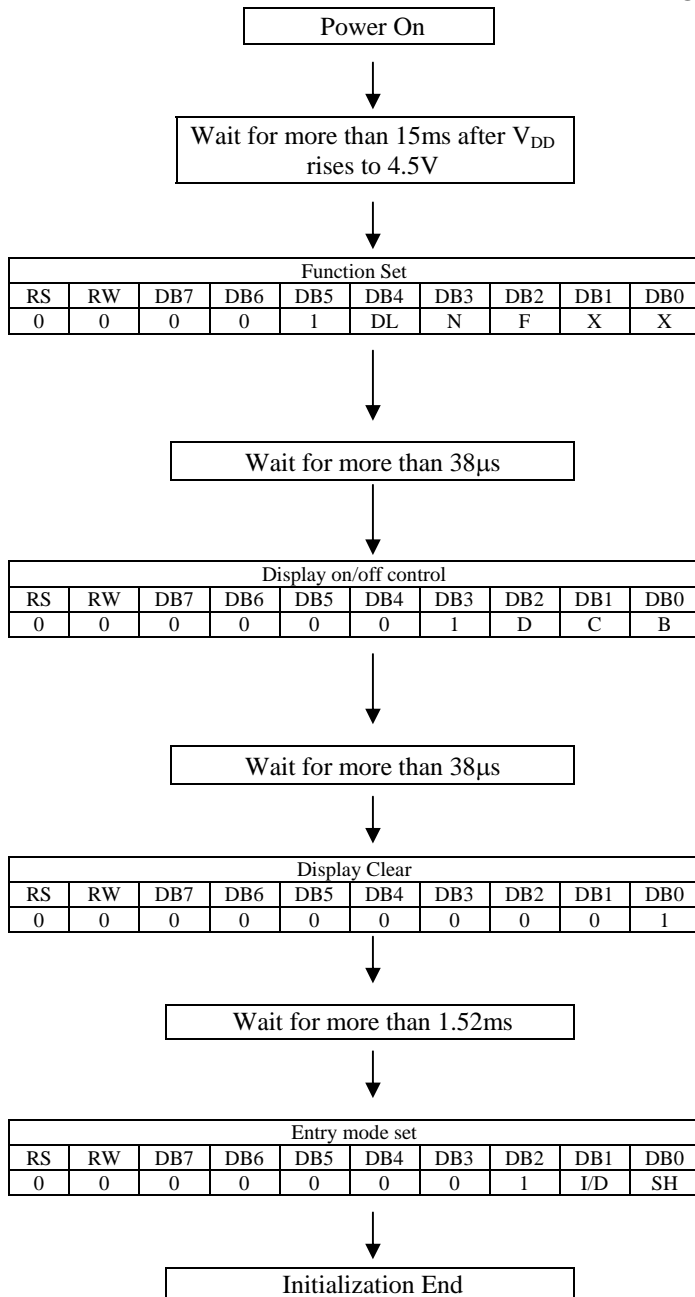

DL	0	4-bit interface
	1	8-bit interface
N	0	1-line mode
	1	2-line mode
F	0	5*7 dots
	1	5*10 dots

D	0	display off
	1	display on
C	0	cursor off
	1	cursor on
B	0	blink off
	1	blink on

I/D	0	decrement mode
	1	increment mode
SH	0	entire shift off
	1	entire shift on



13-3. 4-bit interface mode

Condition: $f_{OSC}=250kHz$

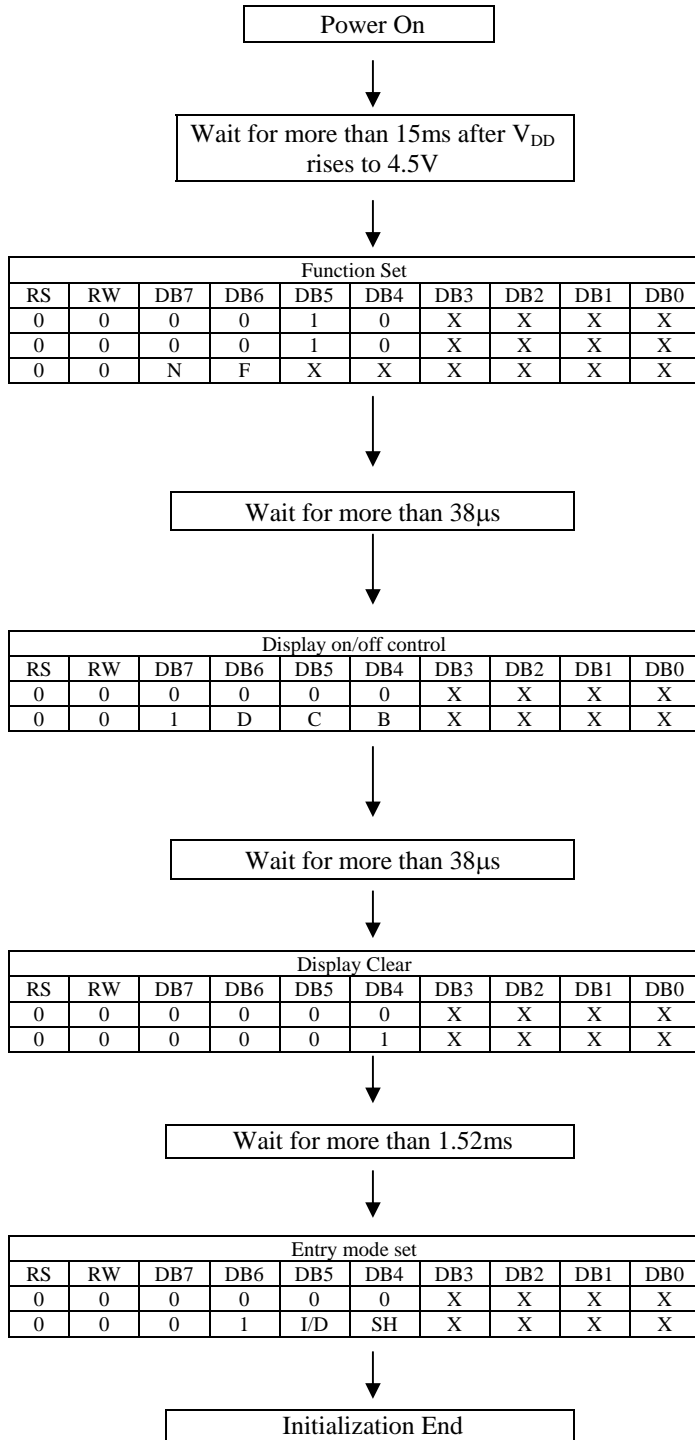

DL	0	4-bit interface
	1	8-bit interface
N	0	1-line mode
	1	2-line mode
F	0	5*7 dots
	1	5*10 dots

D	0	display off
	1	display on
C	0	cursor off
	1	cursor on
B	0	blink off
	1	blink on

I/D	0	decrement mode
	1	increment mode
SH	0	entire shift off
	1	entire shift on



14. SOFTWARE EXAMPLES

1. Power supply on: Initialized by the internal power on reset circuit LCD DISPLAY

RS	R/W	DB7	DB6	DB5	DB4	DB3	DB2	DB1	DB0

2. Function set: 8-bits, 2 lines, 5*7dot

RS	R/W	DB7	DB6	DB5	DB4	DB3	DB2	DB1	DB0
0	0	0	0	1	1	1	0	X	X

3. Display on/off control: Display On / Cursor On/ Blink Off

RS	R/W	DB7	DB6	DB5	DB4	DB3	DB2	DB1	DB0
0	0	0	0	0	0	1	1	1	0

-

4. Entry mode set: Increment

RS	R/W	DB7	DB6	DB5	DB4	DB3	DB2	DB1	DB0
0	0	0	0	0	0	0	1	1	0

-

5. Write data to DDRAM: write T

RS	R/W	DB7	DB6	DB5	DB4	DB3	DB2	DB1	DB0
1	0	0	1	0	1	0	1	0	0

T_

6. Write data to DDRAM: write R

RS	R/W	DB7	DB6	DB5	DB4	DB3	DB2	DB1	DB0
1	0	0	1	0	1	0	0	1	0

TR_

7. Write data to DDRAM: write T

RS	R/W	DB7	DB6	DB5	DB4	DB3	DB2	DB1	DB0
1	0	0	1	0	1		1	0	0

TRI-T

8. Write Second Line Command: 0x40

RS	R/W	DB7	DB6	DB5	DB4	DB3	DB2	DB1	DB0
0	0	1	1	0	0	0	0	0	0

TRI-T
_

9. Write data to DDRAM: write E

RS	R/W	DB7	DB6	DB5	DB4	DB3	DB2	DB1	DB0
1	0	0	1	0	1	0	1	0	0

TRI-T
T_

10. Return Home

RS	R/W	DB7	DB6	DB5	DB4	DB3	DB2	DB1	DB0
0	0	0	0	0	0	0	0	1	X

TRI-T
TMBC

11. Clear Display

RS	R/W	DB7	DB6	DB5	DB4	DB3	DB2	DB1	DB0
0	0	0	0	0	0	0	0	0	1

-

X: Don't care



15. Quality Specifications

15-1. Standard of the product appearance test

Manner of appearance test: The inspection should be performed in using 20W x 2 fluorescent lamps. Distance between LCM and fluorescent lamps should be 100 cm or more. Distance between LCM and inspector eyes should be 30 cm or more.

Viewing direction for inspection is 45° from vertical against LCM.

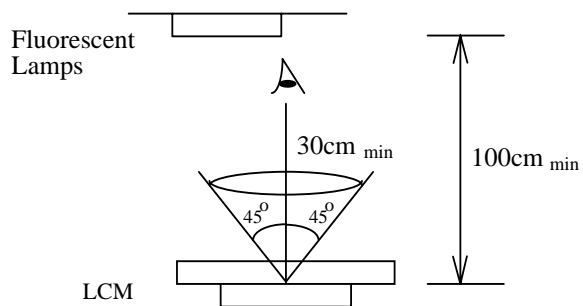

Definition of zone:

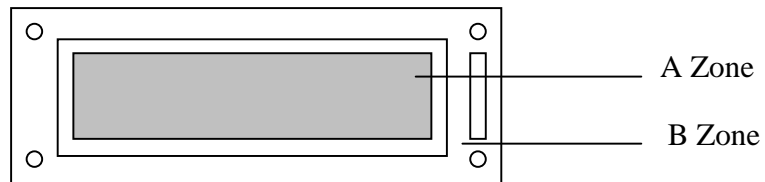

A Zone: Display area (LCD)

B Zone: PCB



15-2. Specification of quality assurance

AQL inspection standard

Sampling method: MIL-STD-105E, Level II, single sampling

Defect classification

Classify	Item		Note	AQL
Major	Display state	Short or open circuit	1	0.65
		Contrast defect (dim, ghost)		
		LC leakage		
		Flickering		
		No display		
		Wrong viewing direction	2	
		Wrong Back-light	7	
	Non-display	Flat cable or pin reverse	9	
		Wrong or missing component	10	
Minor	Display state	Background color deviation	2	1.5
		Black spot and dust	3	
		Line defect	4	
		Scratch		
		Rainbow	5	
		Pin hole	6	
	Polarizer	Bubble and foreign material	3	
		Scratch	4	
	PCB	Scratch	4	
	Soldering	Poor connection	8	
	Wire	Poor connection	9	

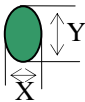
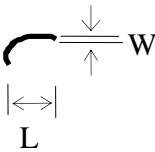

Note on defect classification

No.	Item	Criterion																				
1	Short or open circuit	Not allow																				
	LC leakage																					
	Flickering																					
	No display																					
	Wrong viewing direction																					
	Wrong Back-light																					
2	Contrast defect	Refer to approval sample																				
	Background color deviation																					
3	Point defect, Black spot, dust (incl. Polarizer) $\phi = (X+Y)/2$	 <table border="1" data-bbox="916 1016 1342 1308"> <thead> <tr> <th>Point Size</th> <th>Acceptable Qty.</th> </tr> </thead> <tbody> <tr> <td>$\phi \leq 0.10$</td> <td>Disregard</td> </tr> <tr> <td>$0.10 < \phi \leq 0.20$</td> <td>3</td> </tr> <tr> <td>$0.20 < \phi \leq 0.25$</td> <td>2</td> </tr> <tr> <td>$0.25 < \phi \leq 0.30$</td> <td>1</td> </tr> <tr> <td>$\phi > 0.30$</td> <td>0</td> </tr> </tbody> </table> <p>Unit: mm</p>	Point Size	Acceptable Qty.	$\phi \leq 0.10$	Disregard	$0.10 < \phi \leq 0.20$	3	$0.20 < \phi \leq 0.25$	2	$0.25 < \phi \leq 0.30$	1	$\phi > 0.30$	0								
Point Size	Acceptable Qty.																					
$\phi \leq 0.10$	Disregard																					
$0.10 < \phi \leq 0.20$	3																					
$0.20 < \phi \leq 0.25$	2																					
$0.25 < \phi \leq 0.30$	1																					
$\phi > 0.30$	0																					
4	Line defect	 <table border="1" data-bbox="847 1473 1382 1727"> <thead> <tr> <th colspan="2">Line</th> <th>Acceptable Qty.</th> </tr> <tr> <th>L</th> <th>W</th> <th></th> </tr> </thead> <tbody> <tr> <td>---</td> <td>$0.015 \geq W$</td> <td>Disregard</td> </tr> <tr> <td>$3.0 \geq L$</td> <td>$0.03 \geq W$</td> <td rowspan="2">2</td> </tr> <tr> <td>$2.0 \geq L$</td> <td>$0.05 \geq W$</td> </tr> <tr> <td>$1.0 \geq L$</td> <td>$0.1 > W$</td> <td>1</td> </tr> <tr> <td>---</td> <td>$0.05 < W$</td> <td>Applied as point defect</td> </tr> </tbody> </table> <p>Unit: mm</p>	Line		Acceptable Qty.	L	W		---	$0.015 \geq W$	Disregard	$3.0 \geq L$	$0.03 \geq W$	2	$2.0 \geq L$	$0.05 \geq W$	$1.0 \geq L$	$0.1 > W$	1	---	$0.05 < W$	Applied as point defect
Line		Acceptable Qty.																				
L	W																					
---	$0.015 \geq W$	Disregard																				
$3.0 \geq L$	$0.03 \geq W$	2																				
$2.0 \geq L$	$0.05 \geq W$																					
$1.0 \geq L$	$0.1 > W$	1																				
---	$0.05 < W$	Applied as point defect																				
5	Rainbow	Not more than two color changes across the viewing area.																				

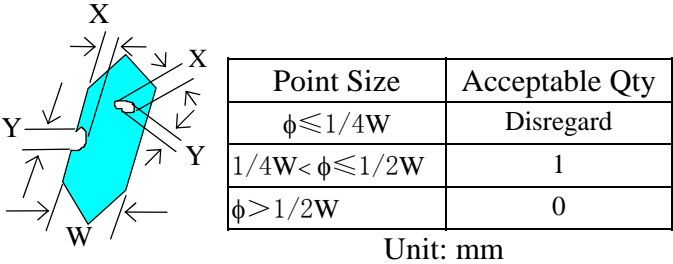
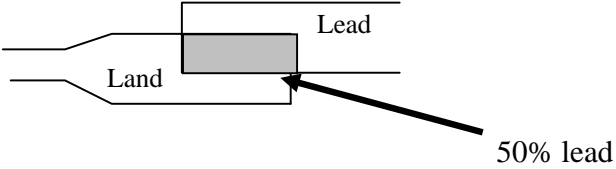

No.	Item	Criterion								
6	Segment pattern $W = \text{Segment width}$ $\phi = (X+Y)/2$	(1) Pin hole $\phi < 0.10\text{mm}$ is acceptable.  <table border="1" data-bbox="908 640 1358 813"> <thead> <tr> <th>Point Size</th> <th>Acceptable Qty</th> </tr> </thead> <tbody> <tr> <td>$\phi \leq 1/4W$</td> <td>Disregard</td> </tr> <tr> <td>$1/4W < \phi \leq 1/2W$</td> <td>1</td> </tr> <tr> <td>$\phi > 1/2W$</td> <td>0</td> </tr> </tbody> </table> <p style="text-align: center;">Unit: mm</p>	Point Size	Acceptable Qty	$\phi \leq 1/4W$	Disregard	$1/4W < \phi \leq 1/2W$	1	$\phi > 1/2W$	0
Point Size	Acceptable Qty									
$\phi \leq 1/4W$	Disregard									
$1/4W < \phi \leq 1/2W$	1									
$\phi > 1/2W$	0									
7	Back-light	(1) The color of backlight should correspond its specification. (2) Not allow flickering								
8	Soldering	(1) Not allow heavy dirty and solder ball on PCB. (The size of dirty refer to point and dust defect) (2) Over 50% of lead should be soldered on Land. 								
9	Wire	(1) Copper wire should not be rusted (2) Not allow crack on copper wire connection. (3) Not allow reversing the position of the flat cable. (4) Not allow exposed copper wire inside the flat cable.								
10	PCB	(1) Not allow screw rust or damage. (2) Not allow missing or wrong putting of component.								



15-3. Reliability of LCM

Reliability test condition:

Item	Condition	Time (hrs)	Assessment
High temp. Storage	80°C	240	No abnormalities in functions and appearance
High temp. Operating	70°C	240	
Low temp. Storage	-30°C	240	
Low temp. Operating	-20°C	240	
Humidity	40°C/ 90%RH	240	
Temp. Cycle	-30°C ← 25°C → 80°C (30 min ← 5 min → 30min)	10cycles	

Recovery time should be 24 hours minimum. Moreover, functions, performance and appearance shall be free from remarkable deterioration within 50,000 hours under ordinary operating and storage conditions room temperature (20±8°C), normal humidity (below 65% RH), and in the area not exposed to direct sun light.



15-4. Precaution for using LCM

LCM is assembled and adjusted with a high degree of precision. Do not attempt to make any alteration or modification. The followings should be noted.

General Precautions:

1. LCD panel is made of glass. Avoid excessive mechanical shock or applying strong pressure onto the surface of display area.
2. The polarizer used on the display surface is easily scratched and damaged. Extreme care should be taken when handling. To clean dust or dirt off the display surface, wipe gently with cotton, or other soft material soaked with isopropyl alcohol, ethyl alcohol or trichlorotrifluoroethane, do not use water, ketone or aromatics and never scrub hard.
3. Do not tamper in any way with the tabs on the metal frame.
4. Do not make any modification on the PCB without consulting TRI-T.
5. When mounting a LCM, make sure that the PCB is not under any stress such as bending or twisting. Elastomer contacts are very delicate and missing pixels could result from slight dislocation of any of the elements.
6. Avoid pressing on the metal bezel, otherwise the elastomer connector could be deformed and lose contact, resulting in missing pixels and also cause rainbow on the display.
7. Be careful not to touch or swallow liquid crystal that might leak from a damaged cell. Any liquid crystal adheres to skin or clothes, wash it off immediately with soap and water.

Static Electricity Precautions:

1. CMOS-LSI is used for the module circuit; therefore operators should be grounded whenever he/she comes into contact with the module.
2. Do not touch any of the conductive parts such as the LSI pads; the copper leads on the PCB and the interface terminals with any parts of the human body.
3. Do not touch the connection terminals of the display with bare hand; it will cause disconnection or defective insulation of terminals.
4. The modules should be kept in anti-static bags or other containers resistant to static for storage.
5. Only properly grounded soldering irons should be used.
6. If an electric screwdriver is used, it should be grounded and shielded to prevent sparks.
7. The normal static prevention measures should be observed for work clothes and working benches.
8. Since dry air is inductive to static, a relative humidity of 50-60% is recommended.



TRI-T COMPANY LIMITED

Soldering Precautions:

1. Soldering should be performed only on the I/O terminals.
2. Use soldering irons with proper grounding and no leakage.
3. Soldering temperature: $280^{\circ}\text{C}\pm 10^{\circ}\text{C}$
4. Soldering time: 3 to 4 second.
5. Use eutectic solder with resin flux filling.
6. If flux is used, the LCD surface should be protected to avoid spattering flux.
7. Flux residue should be removed.

Operation Precautions:

1. The viewing angle can be adjusted by varying the LCD driving voltage V_o .
2. Since applied DC voltage causes electro-chemical reactions, which deteriorate the display, the applied pulse waveform should be a symmetric waveform such that no DC component remains. Be sure to use the specified operating voltage.
3. Driving voltage should be kept within specified range; excess voltage will shorten display life.
4. Response time increases with decrease in temperature.
5. Display color may be affected at temperatures above its operational range.

Operation Precautions:

1. Keep the temperature within the specified range usage and storage. Excessive temperature and humidity could cause polarization degradation, polarizer peel-off or generate bubbles.
2. For long-term storage over 40°C is required, the relative humidity should be kept below 60%. Avoid direct sunlight.

Limited Warranty

TRI-T modules are not consumer products, but may be incorporated by TRI-T's customers into consumer products or components thereof, TRI-T does not warrant that its modules and components are fit for any such particular purpose.

1. The liability of TRI-T is limited to repair or replacement on the terms set forth below. TRI-T will not be responsible for any subsequent or consequential events or injury or damage to any personnel or user including third party personnel and/or user. Unless otherwise agreed in writing between TRI-T and the customer, TRI-T will only replace or repair any of its LCD which is found defective electrically or visually when inspected in accordance with TRI-T QUALITY INSPECTION STANDARD.
2. No warranty can be granted if any of the precautions state in handling liquid crystal display above has been disregarded. Broken glass, scratches on polarizer mechanical damages as well as defects that are caused accelerated environment tests are excluded from warranty.
3. In returning the LCM, they must be properly packaged; there should be detailed description of the failures or defect.